

1. **Dibuja las vistas de las piezas de la derecha. Colorea cada cara de la perspectiva y su vista correspondiente con un mismo color.**

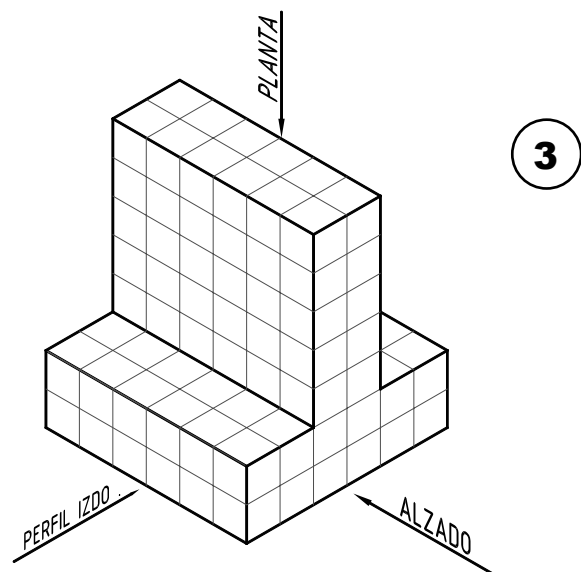

2. Dibuja las vistas de las piezas de la derecha.

<i>PERFIL DERECHO</i>	<i>ALZADO</i>
	<i>PLANTA</i>

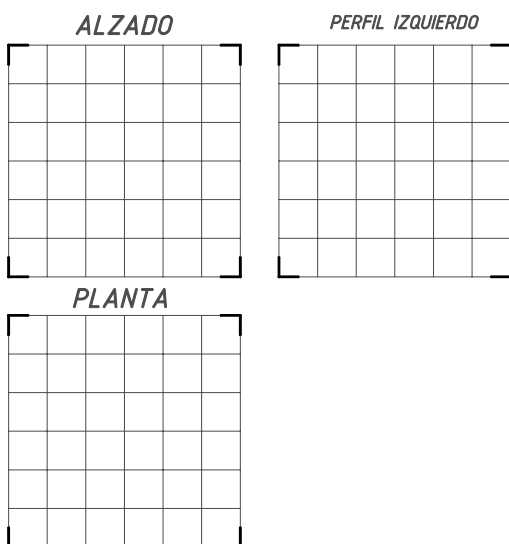
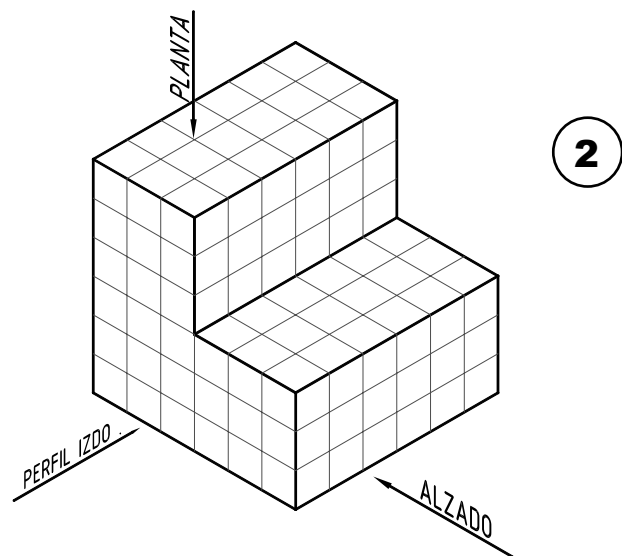
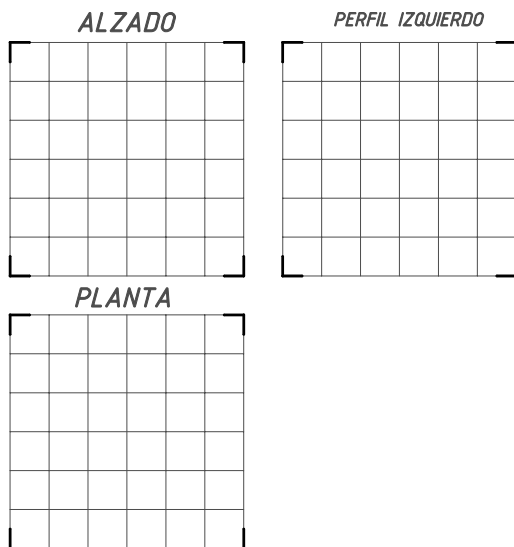
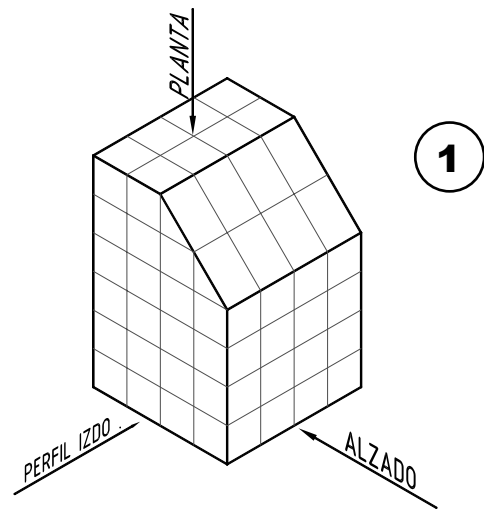
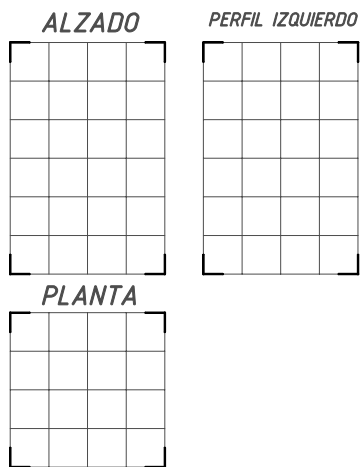
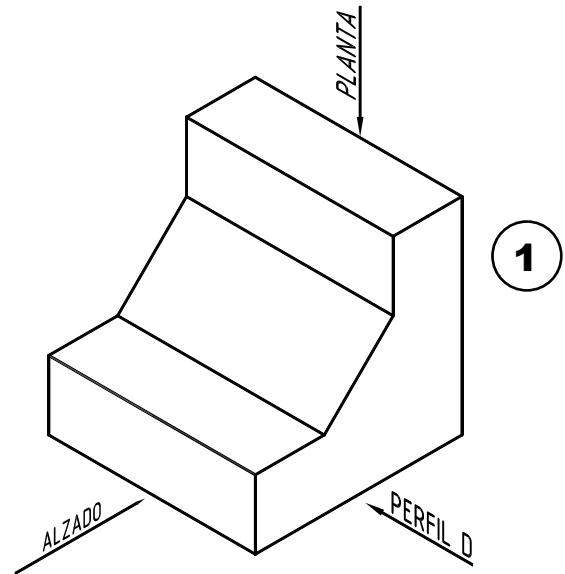

<i>PERFIL DERECHO</i>	<i>ALZADO</i>
	<i>PLANTA</i>

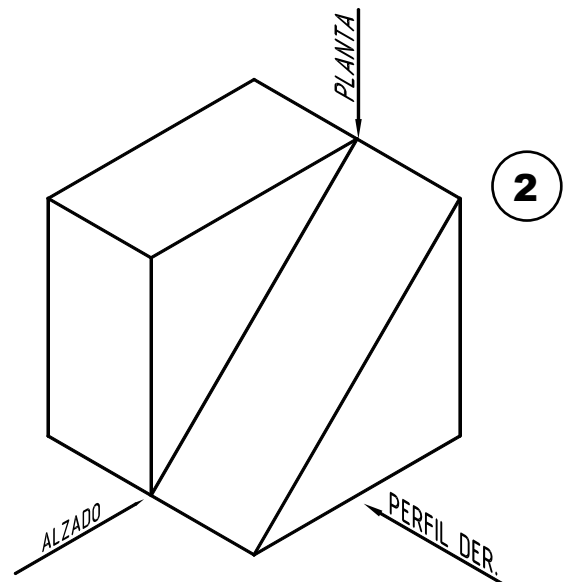

<i>ALZADO</i>	<i>PERFIL IZQUIERDO</i>
<i>PLANTA</i>	

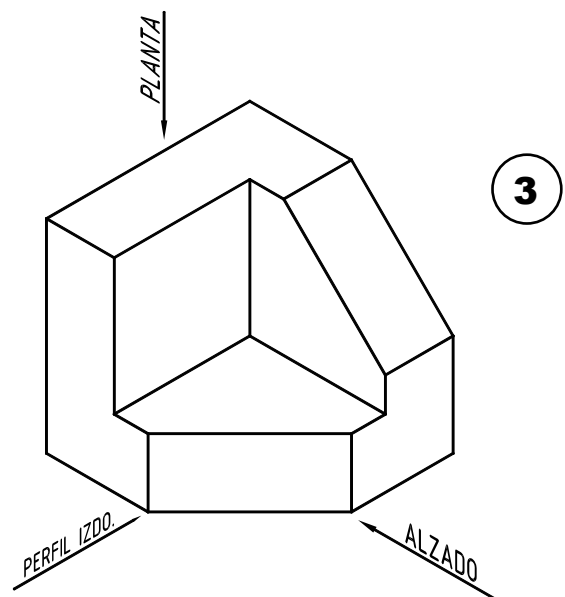

3. **Dibuja las vistas de las piezas de la derecha. Elige el punto de vista más adecuado.**

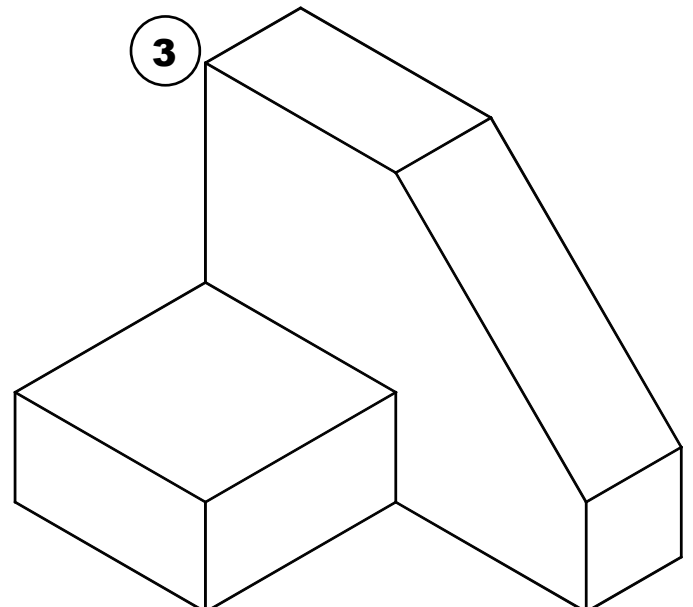
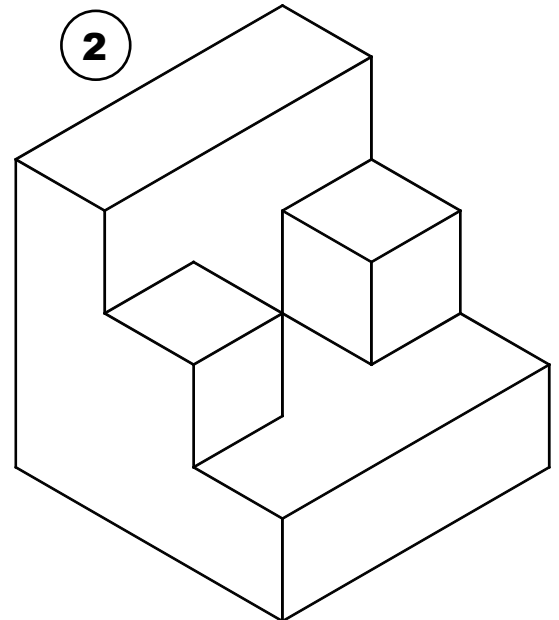
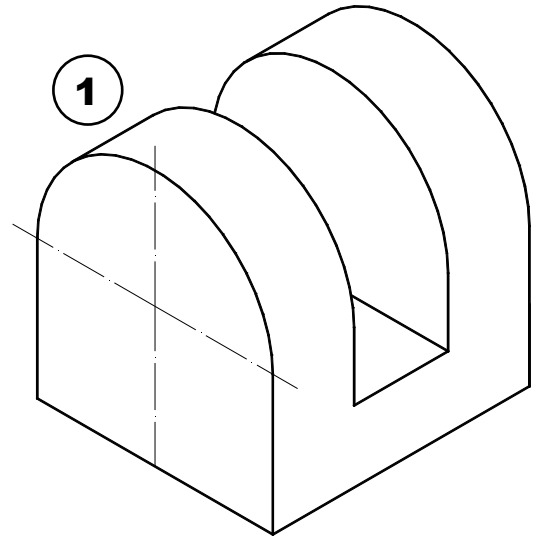

4. Dibuja las tres vistas principales de las siguientes piezas:

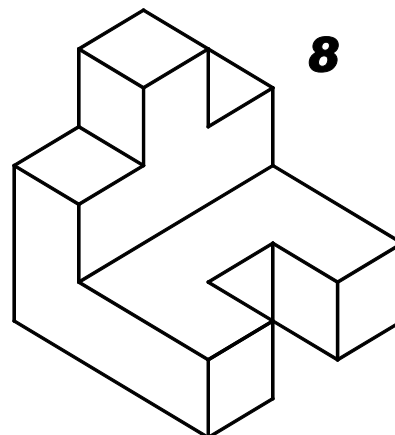
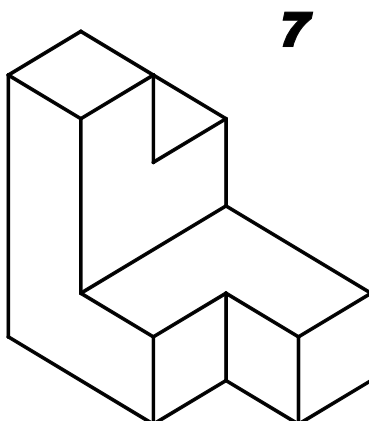
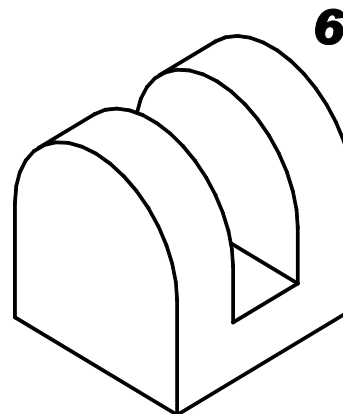
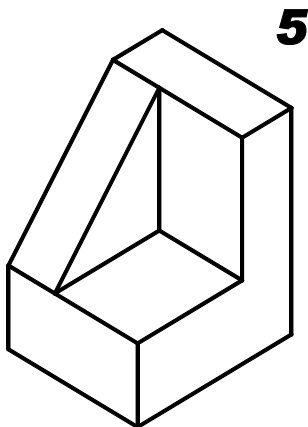
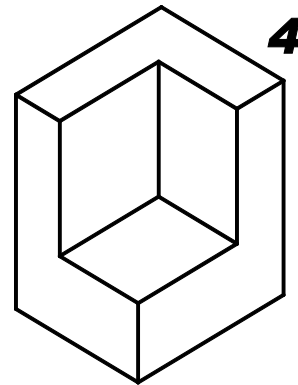
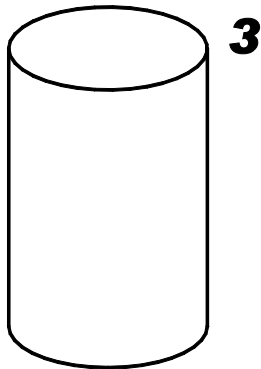
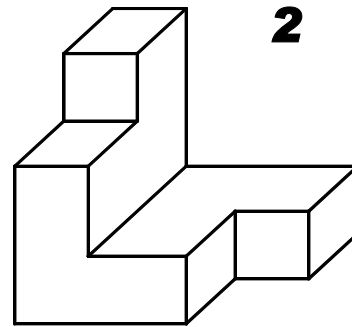
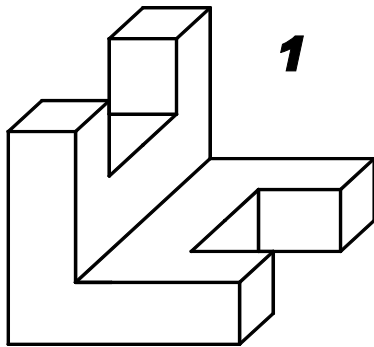

5. Dibuja las vistas de las siguientes piezas respetando las dimensiones que se indican.

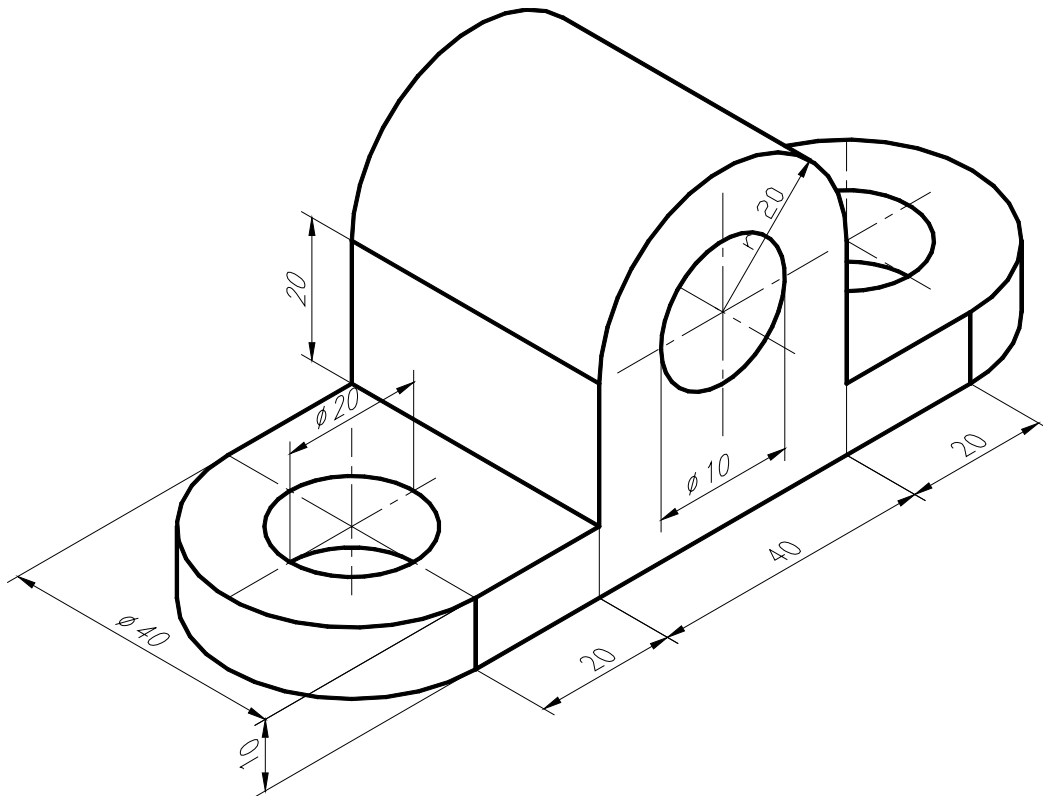
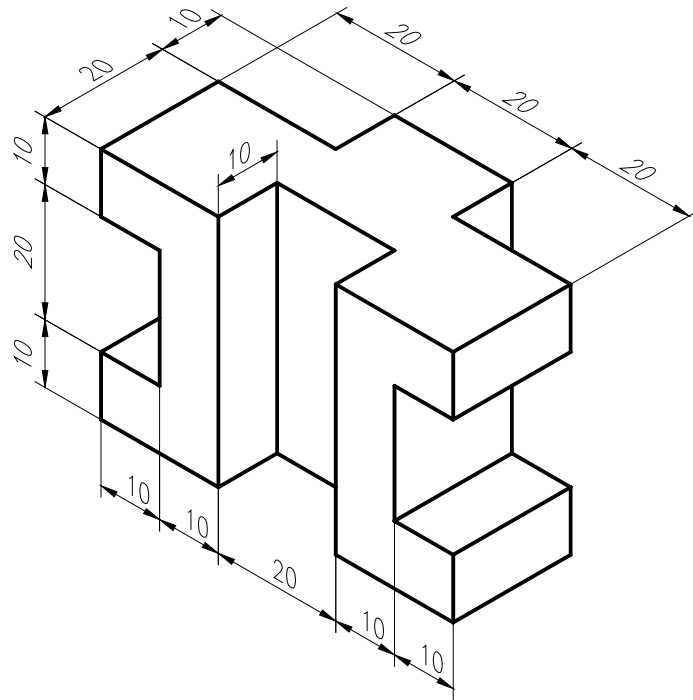

6. Dibuja las vistas de las piezas siguientes, aplicando la escala que se indica junto a ellas. Acótalas correctamente.

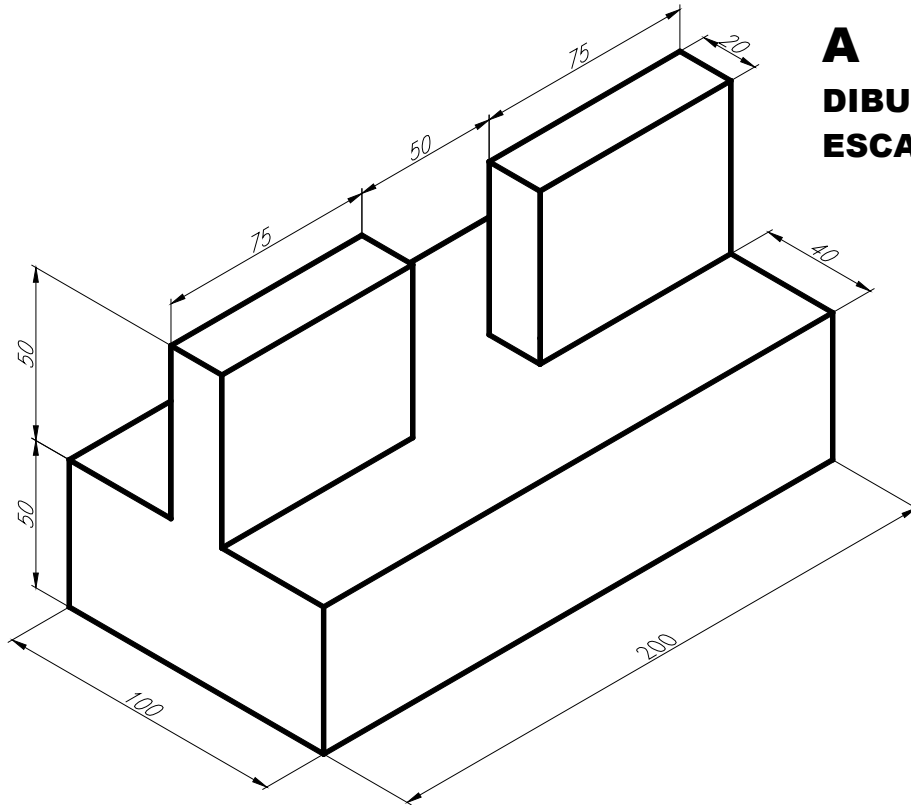

**A**  
**DIBUJAR A**  
**ESCALA 1:2**

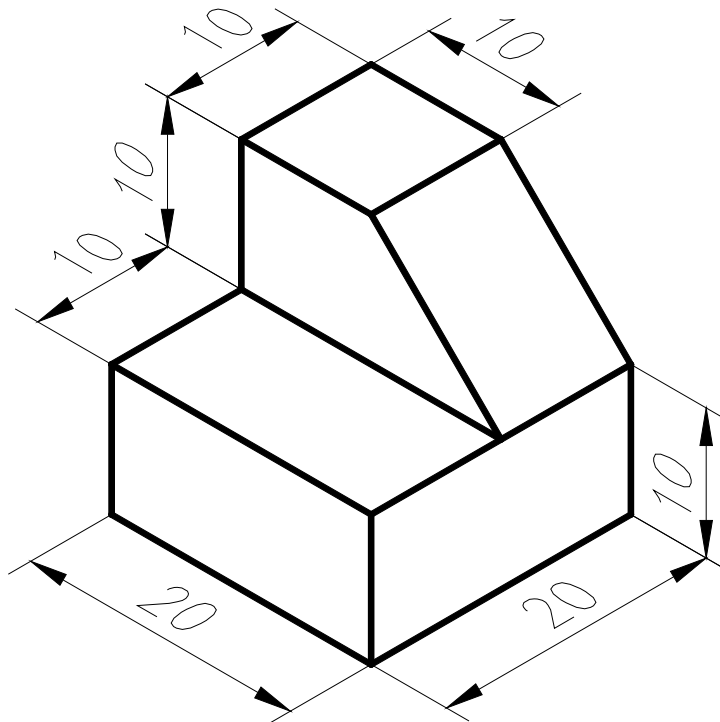

**B**  
**DIBUJAR A**  
**ESCALA 2:1**

**7. EJERCICIOS DE AMPLIACIÓN.**

**Dibuja las vistas de las piezas siguientes, aplicando la escala que se indica junto a ellas. Acótalas correctamente.**

